

# KOMATSU®

## WA380-6

### With Tier 3 Engine

**NET HORSEPOWER**

142 kW **191 HP** @ 2100 rpm

**OPERATING WEIGHT**

17580 - 17960 kg

**38,760 - 39,600 lb**

**BUCKET CAPACITY**

2.9 - 4.0 m<sup>3</sup> **3.8 - 5.2 yd<sup>3</sup>**

**WA**  
**380**



W  
H  
E  
E  
L  
L  
O  
A  
D  
E  
R

Photos may include optional equipment.

## WALK-AROUND

***Komatsu-integrated design*** offers the best value, reliability, and versatility. Hydraulics, powertrain, frame, and all other major components are engineered by Komatsu. You get a machine whose components are designed to work together for higher production, greater reliability, and more versatility.

### ***High Productivity & Low Fuel Consumption***

- High performance SAA6D107E engine
- Low fuel consumption
- Dual-mode engine power select system
- Automatic transmission with shift timing select system
- Variable displacement piston pump & Closed-Center Load Sensing System (CLSS)

### ***Excellent Operator Environment***

- Automatic transmission with Electronically Controlled Modulation Valve (ECMV)
- Electrically controlled transmission lever
- Variable transmission cut-off system
- Telescopic/tilt steering column
- Fingertip control levers
- Low-noise designed cab
- Large ROPS/FOPS cab-integrated
- Easy entry/exit, rear-hinged doors



### **KOMTRAX™**

KOMTRAX equipped machines can send location, SMR and operation maps to a secure website utilizing wireless technology. Machines also relay error codes, cautions, maintenance items, fuel levels, and much more.

**NET HORSEPOWER**  
142 kW 191 HP @ 2100 rpm

**OPERATING WEIGHT**  
17580 - 17960 kg  
**38,760 - 39,600 lb**

**BUCKET CAPACITY**  
2.9 - 4.0 m<sup>3</sup> **3.8 - 5.2 yd<sup>3</sup>**

### *Increased Reliability*

- Reliable Komatsu designed and manufactured components
- Sturdy main frame
- Maintenance-free, fully hydraulic, wet disc service and parking brakes
- Hydraulic hoses use flat face O-ring seals
- Sealed DT connectors for electrical connections



### *Easy Maintenance*

- Equipment Management Monitoring System (EMMS)
- Easy access, gull-wing type engine side doors
- Automatic reversible fan

### *Environmentally Friendly*

- EPA Tier 3 and EU stage 3A emissions certified
- Low exterior noise
- Low fuel consumption

Photos may include optional equipment.

## HIGH PRODUCTIVITY AND LOW FUEL CONSUMPTION



ecology & economy - technology 3

Komatsu's new "ecot3" engines are designed to deliver optimum performance under the toughest of conditions,

while meeting the latest environmental regulations. This engine is EPA Tier 3, EU Stage 3A and Japan emissions certified; "ecot3" - ecology and economy combine with Komatsu technology to create a high performance engine without sacrificing power or productivity.

### High Performance SAA6D107E Engine

Electronic Heavy Duty Common Rail fuel injection system provides optimum combustion of fuel. This system also provides fast throttle response to match the machine's powerful tractive effort and fast hydraulic response.

Net: 142 kW **191 HP**

### Low Emission Engine

This engine meets EPA Tier 3 emission regulations and EU stage 3A emission regulations, without sacrificing power or machine productivity.

### Low Fuel Consumption

The fuel consumption is greatly reduced because of the low-noise, high-torque engine and large-capacity torque converter. This matched combination provides maximum efficiency in the low-speed range.

### Dual-Mode Engine Power Select System

This wheel loader offers two selectable operating modes—E and P. The operator can adjust the machine's performance with the selection switch.

- **E Mode:** This mode provides maximum fuel efficiency for general loading.
- **P Mode:** This mode provides maximum power output for hard digging operation or hill climb.



Dual mode engine power selection switch

### Eco Indicator

The Eco Indicator will inform the operator when the machine is maximizing fuel efficiency.



Eco indicator

### Automatic Transmission with Mode Select System

This operator controlled system allows the selection of manual shifting or two levels of automatic shifting modes

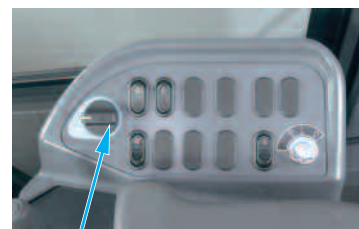

Shift mode selection switch

(low and high). The operator can match the machine's operating requirements with optimum performance efficiency. This system is controlled with a dial on the right control panel.

- **Manual:** The transmission is fixed to the gear speed and selected with the gear lever.
- **Auto Low:** Low mode provides smooth gear shifting at low engine speeds suitable for general excavating and loading while offering reduced fuel consumption.
- **Auto High:** High mode provides maximum rim pull and fast cycle times by shifting the transmission at high engine speeds. This mode is suitable for hill-climb and load and carry operations

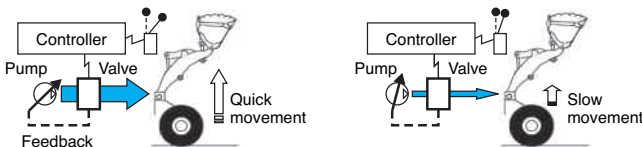

Photo may include optional equipment.

**Variable Displacement Piston Pump and CLSS**

New design variable displacement piston pump combined with the Closed-center Load Sensing System (CLSS) delivers hydraulic flow just as the job requires preventing wasted hydraulic flow. Minimized waste loss contributes to better fuel economy.

- **New Variable Displacement Piston Pump:** The pump delivers only necessary amounts minimizing waste loss.



- **Fixed Displacement Piston Pump:** The pump delivers the maximum amount at any time and the unused flow is disposed.

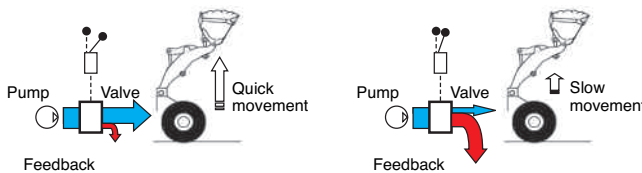

**Maximum Dumping Clearance and Reach**

The long lift arms provide high dumping clearances and maximum dumping reach.

**Dumping Clearance:** 2950 mm 9'8"

**Dumping Reach:** 1150 mm 3'9"

(3.3 m<sup>3</sup> 4.3 yd<sup>3</sup> bucket with B.O.C.)

**Lock-Up Torque Converter (option)**

The Komatsu designed lock-up torque converter provides increased production efficiency, reduced cycle times and optimum fuel savings in load & carry or hill-climb operations. This optional feature allows the operator to activate the system on/off with a switch located on the right-side control panel.

## INCREASED RELIABILITY

### Komatsu Components

Komatsu manufactures the engine, torque converter, transmission, hydraulic units and electric parts on this wheel loader. Komatsu loaders are manufactured with an integrated production system under a strict quality control system.

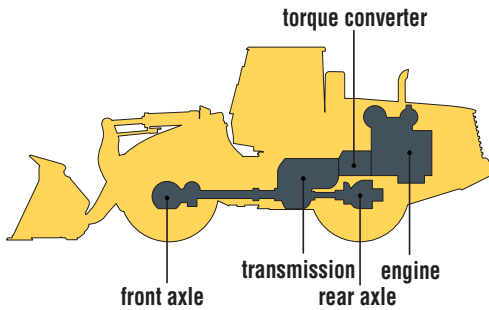

### Wet multi-disc brakes and fully hydraulic braking system

result in lower maintenance costs and higher reliability. The wet disc service and parking brakes are fully sealed and adjustment-free to reduce contamination, wear and maintenance. Added reliability is designed into the braking system by the use of two independent hydraulic circuits providing hydraulic backup should one of the circuits fail. If the brake oil pressure drops, a warning lamp flashes and an alarm sounds intermittently. If the brake pressure continues to drop, the parking brake is automatically applied.

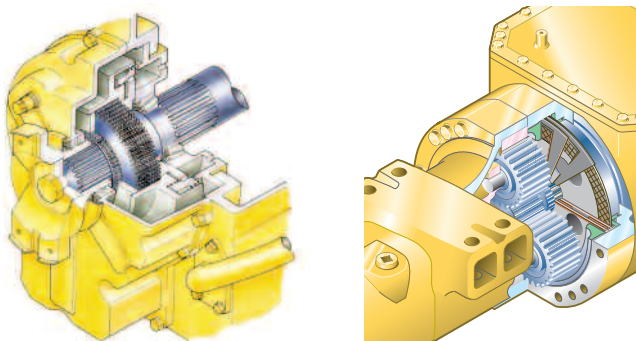

### High-Rigidity Frames and Loader Linkage

The front and rear frames along with the loader linkage have high rigidity to withstand repeated twisting and bending loads to the loader body and linkage, Both the upper and lower center pivot bearings use tapered roller bearings for increased durability

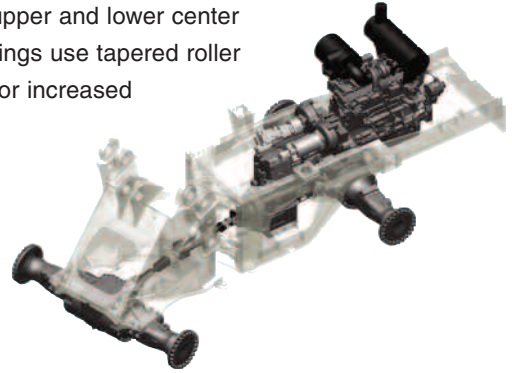

### Flat Face-to-Face O-Ring Seals

Flat face-to-face O-ring seals are used to securely seal hydraulic hose connections and prevent oil leakage.

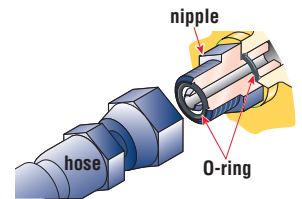

### Cylinder Buffer Rings

Buffer rings are installed to the head-side of the all-hydraulic cylinders to lower the load on the rod seals, prolong cylinder life by 30% and maximize overall reliability.

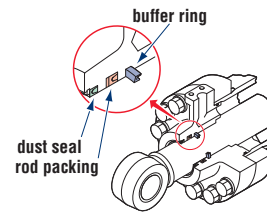

### Sealed DT Connectors

Main harnesses and controller connectors are equipped with sealed DT connectors providing high reliability, dust and corrosion resistance.



# EASY MAINTENANCE



Photo may include optional equipment.

## Main Monitor-EMMS (Equipment Management Monitoring System)

Komatsu's new main monitor keeps the operator informed of all



machine functions at a glance. The monitor is located behind the steering wheel and displays different machine functions including fluid/filter change intervals and troubleshooting memory display functions. The main gauges are analog type for easy viewing and other functions utilize lighted symbols or LCD readouts.

### Maintenance Control and Troubleshooting Functions

- **Action code display function:** If an abnormality occurs, the monitor displays action details on the character display at the bottom center of the monitor.
- **Monitor function:** Controller monitors engine oil level, pressure, coolant temperature, air cleaner clogging, etc. If controller finds abnormalities, the error is displayed on LCD.
- **Replacement time notice function:** Monitor informs replacement time of oil and filters on LCD when replacement intervals are reached.
- **Trouble data memory function:** Monitor stores abnormalities for effective troubleshooting.

## Full Side-Opening Gull-Wing Engine Doors

Ground level engine service and daily service checks are made easy with the gas spring assisted full side-opening gull-wing doors.

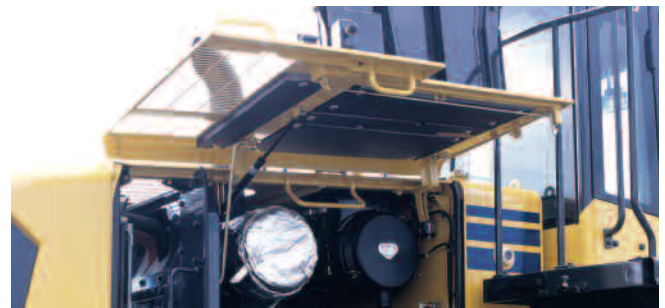

## Easy Radiator Cleaning

If the machine is operating in adverse conditions, the operator can reverse the hydraulic cooling fan from inside the cab by pressing a switch on the control panel.

### Automatic Reversible Fan

The engine fan is driven hydraulically and can be operated in reverse automatically. When the switch is in the automatic position, the fan revolves in reverse for 2 minutes every 2 hours intermittently (default setting).

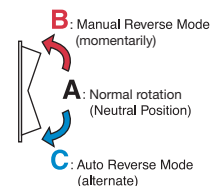

# OPERATOR ENVIRONMENT

## Easy Operation

### Automatic Transmission with Electronically Controlled Modulation Valve (ECMV)

Automatic transmission with ECMV (Electronically Controlled Modulation Valve) automatically selects the proper gear speed based on travel speed, engine speed, and other travel conditions. The ECMV system engages the clutch smoothly to prevent lags and shocks when shifting. This system provides efficient machine operation and a comfortable ride.

- **Kick-down switch:**

Consider this valuable feature for added productivity. With the touch of a finger, the kick-down switch automatically

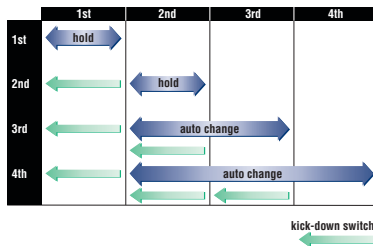

downshifts from second to first when beginning the digging cycle. It automatically upshifts from first to second when the direction control lever is placed in reverse. This results in increased rim pull for better bucket penetration and reduced cycle times for higher productivity.

- **One push power-up function:** The kick-down switch also functions as a power-up switch in first gear. The first time the kick-down switch is depressed, it functions as a kick-down switch and gear speed is reduced. When the machine is in E operation mode and first gear, pressing the kick-down switch a second time changes the operation mode to P allowing increased power for heavy digging operation. The operation mode returns to E when machine gear speed changes or direction changes to reverse.

- **Hold switch:** Auto shift is selected and if the operator turns on this switch when the lever is at the 3rd or 4th gear speed position, the transmission is fixed to that gear speed.

### Electrically Controlled Transmission Levers



The Komatsu two-lever electronic shift control levers provide easy gear selection and directional changes. The transmission levers can be operated without removing the operator's hand

from the steering wheel, allowing improved comfort and control. Solid state electronics and conveniently located direction and gear shift controls make this possible. Automatic shifts in ranges two through four keep production high and manual shifting at a minimum.

### Variable Transmission Cut-Off

The operator can select the transmission cut-off pressure desired for the left brake pedal using the switch located on the right-side control panel.

- Higher cut-off pressure allows the transmission to remain engaged at higher engine rpm/hydraulic pressure for increased performance in ramp loading and stockpiling operations.
- Lower cut-off pressure disengages the transmission at lower rpm/hydraulic pressure for more fuel efficient operation on level surfaces.



1: Cut-off ON/OFF switch 2: Cut-off adjustment switch  
3: Fan reverse ON/OFF switch 4: Boom control 5: Bucket control



## Comfortable Operation

### Fingertip Work Equipment Control Levers with Large Arm Rest

New PPC control levers are used for the work equipment. The operator can easily operate the work equipment with fingertip controls, reducing operator fatigue and improving



fine work equipment control and productivity. The PPC control lever column can be slid forward or backward and the large-sized arm rest can be adjusted up or down to provide the

operator with a variety of comfortable operating positions.

### Telescopic/Tilt Steering Column

The operator can both tilt and telescope the steering wheel to allow maximum comfort and control. The two-spoke steering wheel allows maximum visibility of the monitor panel and the forward work environment.



### Low-noise Design

Noise at operator's ear noise level:  
72 dB(A)

Dynamic noise level (outside):  
108 dB(A)

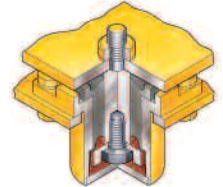

The large cab is mounted with Komatsu's unique ROPS/FOPS viscous mounts. The low-noise engine, hydraulically driven fan, and hydraulic pumps are mounted with rubber cushions, and the cab sealing is improved to provide a quiet, low-vibration, and comfortable operating environment. Pressurization in the cab keeps dirt out further enhancing the operator's comfort.

### Pillar-less Large Cab



A wide pillar-less flat glass provides excellent front visibility. The wiper arm covers a large area to provide great visibility even on rainy days. The cab area is the largest in its class providing maximum space for the operator. The front

mounted air conditioner was introduced to increase seat reclining and backward slide adjustment.

### Rear-hinged Full Open Cab Doors

Entry and exit into the new Komatsu cab starts with sloped staircase type steps and large diameter handrails for added comfort. The large cab doors are rear-hinged to open fully offering easy entry/exit and will not hamper visibility when operating the machine with the doors latched open.



# WA380-6 WHEEL LOADER

## SPECIFICATIONS



### ENGINE

Model ..... Komatsu SAA6D107E  
 Type ..... Water-cooled, 4-cycle  
 Aspiration ..... Turbocharged, aftercooled  
 Number of cylinders ..... 6  
 Bore x stroke ..... 107 mm x 124 mm **4.21" x 4.88"**  
 Piston displacement ..... 6.69 ltr **408 in<sup>3</sup>**  
 Governor ..... All-speed, electronic  
 Horsepower  
 SAE J1995 ..... Gross 143 kW **192 HP**  
 ISO 9249/SAE J1349 ..... Net 142 kW **191 HP**  
 Hydraulic fan at maximum speed ..... Net 133 kW **179 HP**  
 Rated rpm ..... 2100 rpm  
 Fan drive method for radiator cooling ..... Hydraulic  
 Fuel system ..... Direct injection  
 Lubrication system:  
 Method ..... Gear pump, force-lubrication  
 Filter ..... Full-flow type  
 Air cleaner ..... Dry type with double elements and dust evacuator, plus dust indicator



### TRANSMISSION

Torque converter:  
 Type ..... 3-element, single-stage, single-phase  
 Transmission:  
 Type ..... Automatic, full-powershift, countershaft type

Travel speed: km/h **mph**

Measured with 20.5 - 25 tires ( ): Lock-up clutch ON

	1st	2nd	3rd	4th
Forward	6.0 <b>3.7</b>	10.6 <b>6.6</b>	18.6 <b>11.6</b> (19.9 <b>12.4</b> )	31.1 <b>19.3</b> (35.0 <b>21.8</b> )
Reverse	6.5 <b>4.0</b>	11.3 <b>7.0</b>	19.9 <b>12.4</b> (21.3 <b>13.2</b> )	33.0 <b>20.5</b> (37.5 <b>23.3</b> )

Measured with 23.5 - 25 tires ( ): Lock-up clutch ON

	1st	2nd	3rd	4th
Forward	6.6 <b>4.1</b>	11.5 <b>7.1</b>	20.2 <b>12.6</b> (21.7 <b>13.5</b> )	34.0 <b>21.1</b> (35.7 <b>22.2</b> )
Reverse	7.1 <b>4.4</b>	12.3 <b>7.6</b>	21.5 <b>13.4</b> (23.2 <b>14.4</b> )	35.5 <b>22.1</b> (40.9 <b>25.4</b> )



### AXLES AND FINAL DRIVES

Drive system ..... Four-wheel drive  
 Front ..... Fixed, semi-floating  
 Rear ..... Center-pin support, semi-floating,  
 26° total oscillation  
 Reduction gear ..... Spiral bevel gear  
 Differential gear ..... Conventional type  
 Final reduction gear ..... Planetary gear, single reduction



### BRAKES

Service brakes ..... Hydraulically actuated,  
 wet disc brakes actuate on four wheels  
 Parking brake ..... Wet disc brake  
 Emergency brake ..... Parking brake is commonly used



### STEERING SYSTEM

Type ..... Articulated type, full-hydraulic power steering  
 Steering angle ..... 40° each direction  
 Minimum turning radius at  
 the center of outside tire ..... 6320 mm **20'9"**



### HYDRAULIC SYSTEM

Steering system:  
 Hydraulic pump ..... Piston pump  
 Capacity ..... 138 ltr/min **36.5 U.S. gal/min** at rated rpm  
 Relief valve setting ..... 24.5 MPa 250 kgf/cm<sup>2</sup> **3,555 psi**  
 Hydraulic cylinders:  
 Type ..... Double-acting, piston type  
 Number of cylinders ..... 2  
 Bore x stroke ..... 75 mm x 442 mm **3.0" x 17.4"**

Loader control:  
 Hydraulic pump ..... Piston pump  
 Capacity ..... 206 ltr/min **54.4 U.S. gal/min** at rated rpm  
 Relief valve setting ..... 31.4 MPa 320 kgf/cm<sup>2</sup> **4,550 psi**  
 Hydraulic cylinders:  
 Type ..... Double-acting, piston type  
 Number of cylinders—bore x stroke:  
 Boom cylinder ..... 2- 130 mm x 713 mm **5.1" x 28.1"**  
 Bucket cylinder ..... 1- 150 mm x 535 mm **5.9" x 21.1"**  
 Control valve ..... 2-spool type  
 Control positions:  
 Boom ..... Raise, hold, lower, and float  
 Bucket ..... Tilt-back, hold, and dump  
 Hydraulic cycle time (rated load in bucket)  
 Raise ..... 5.9 sec  
 Dump ..... 1.8 sec  
 Lower (Empty) ..... 3.3 sec



### SERVICE REFILL CAPACITIES

Cooling system ..... 20.5 ltr **5.4 U.S. gal**  
 Fuel tank ..... 300 ltr **79.3 U.S. gal**  
 Engine ..... 23 ltr **6.1 U.S. gal**  
 Hydraulic system ..... 139 ltr **36.6 U.S. gal**  
 Axle (each front and rear) ..... 40 ltr **10.6 U.S. gal**  
 Torque converter and transmission ..... 38 ltr **10.0 U.S. gal**



### BUCKET SELECTION GUIDE

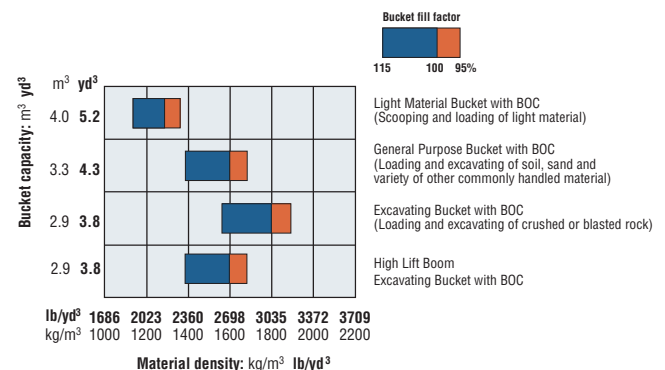

 **DIMENSIONS**

Measured with 23.5-25-16PR(L3) tires, ROPS/FOPS cab

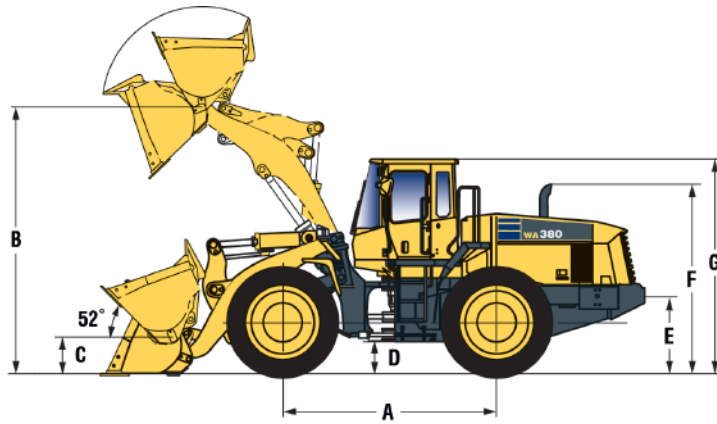

	Tread		2160 mm	7'1"
	Width over tires		2780 mm	9'1"
A	Wheelbase		3300 mm	10'10"
B	Hinge pin height max. height	Standard Boom	4095 mm	13'5"
		High Lift Boom	4625 mm	15'2"
C	Hinge pin height carry position	Standard Boom	520 mm	1'8"
		High Lift Boom	680 mm	2'3"
D	Ground clearance		455 mm	1'6"
E	Hitch height		1150 mm	3'9"
F	Overall height, top of the stack		2975 mm	9'9"
G	Overall height, ROPS cab		3390 mm	11'2"

	General Purpose Bucket	Excavating Bucket	Light Material Bucket	High Lift Boom
	Bolt-on Cutting edge	Bolt-on Cutting edge	Bolt-on Cutting edge	Bolt-on Cutting edge
Bucket capacity: heaped	3.3 m <sup>3</sup>	2.9 m <sup>3</sup>	4.0 m <sup>3</sup>	2.9 m <sup>3</sup>
	<b>4.3 yd<sup>3</sup></b>	<b>3.8 yd<sup>3</sup></b>	<b>5.2 yd<sup>3</sup></b>	<b>3.8 yd<sup>3</sup></b>
struck	2.9 m <sup>3</sup>	2.4 m <sup>3</sup>	3.4 m <sup>3</sup>	2.4 m <sup>3</sup>
	<b>3.8 yd<sup>3</sup></b>	<b>3.1 yd<sup>3</sup></b>	<b>4.4 yd<sup>3</sup></b>	<b>3.1 yd<sup>3</sup></b>
Bucket width	2905 mm <b>9'6"</b>	2905 mm <b>9'6"</b>	2905 mm <b>9'6"</b>	2905 mm <b>9'6"</b>
Bucket weight	1620 kg <b>3,570 lb</b>	1720 kg <b>3,790 lb</b>	1835 kg <b>4,045 lb</b>	1720 kg <b>3,790 lb</b>
Dumping clearance, max. height and 45° dump angle*	2950 mm <b>9'8"</b>	3045 mm <b>10'0"</b>	2855 mm <b>9'4"</b>	3575 mm <b>11'9"</b>
Reach at max. height and 45° dump angle*	1150 mm <b>3'9"</b>	1055 mm <b>3'6"</b>	1240 mm <b>4'1"</b>	1185 mm <b>3'11"</b>
Reach at 2130 mm (7') clearance and 45° dump angle	1735 mm <b>5'8"</b>	1680 mm <b>5'6"</b>	1780 mm <b>5'10"</b>	2205 mm <b>7'3"</b>
Reach with arm horizontal and bucket level	2590 mm <b>8'6"</b>	2450 mm <b>8'0"</b>	2715 mm <b>8'11"</b>	2940 mm <b>9'8"</b>
Operating height (fully raised)	5600 mm <b>18'4"</b>	5470 mm <b>17'11"</b>	5720 mm <b>18'9"</b>	5985 mm <b>19'7"</b>
Overall length	8140 mm <b>26'8"</b>	8000 mm <b>26'3"</b>	8265 mm <b>27'1"</b>	8780 mm <b>28'10"</b>
Loader clearance circle (bucket at carry, outside corner of bucket)	14440 mm <b>47'5"</b>	14370 mm <b>47'2"</b>	14500 mm <b>47'7"</b>	14850 mm <b>48'9"</b>
Digging depth: 0°	60 mm <b>2.4"</b>	60 mm <b>2.4"</b>	60 mm <b>2.4"</b>	110 mm <b>4.3"</b>
	10°	290 mm <b>11.4"</b>	265 mm <b>10.4"</b>	315 mm <b>1'0"</b>
Static tipping load: straight	14560 kg <b>32,100 lb</b>	14460 kg <b>31,880 lb</b>	14330 kg <b>31,590 lb</b>	12080 kg <b>26,630 lb</b>
	40° full turn	12610 kg <b>27,800 lb</b>	12505 kg <b>27,570 lb</b>	12375 kg <b>27,280 lb</b>
Breakout force	158 kN	176 kN	144 kN	183 kN
	16100 kgf <b>35,495 lb</b>	18000 kgf <b>39,680 lb</b>	14700 kgf <b>32,405 lb</b>	18700 kgf <b>41,220 lb</b>
Operating weight	17580 kg <b>38,760 lb</b>	17960 kg <b>39,600 lb</b>	17810 kg <b>39,260 lb</b>	18530 kg <b>40,850 lb</b>

\* At the end of B.O.C.

All dimensions, weights, and performance values based on SAE J732c and J742b standards.

Static tipping load and operating weight shown include lubricant, coolant, full fuel tank, ROPS cab, and operator. Machine stability and operating weight affected by counterweight, tire size, and other attachments.

Apply the following weight changes to operating weight and static tipping load.



## WEIGHT CHANGES

Apply the following weight changes to operating weight and static tipping load.

Tires or Attachments	Operating Weight		Tipping Load Straight		Tipping Load Full Turn		Width Over Tires		Ground Clearance		Change in Vertical Dimensions	
	kg	lb	kg	lb	kg	lb	mm	ft in	mm	ft in	mm	ft in
20.5-25-16PR(L-3)	-1080	<b>-2381</b>	-740	<b>-1632</b>	-650	<b>-1433</b>	2780	<b>9'1"</b>	455	<b>1'6"</b>	-65	<b>-3"</b>
OPT counterweight	+340	<b>+750</b>	+900	<b>+1,985</b>	+755	<b>+1,665</b>						



## STANDARD EQUIPMENT

- 2-spool valve for boom and bucket controls
- Air conditioner
- Alternator, 60 A
- Auto shift transmission with mode select system
- Automatic hydraulic-driven fan with reverse rotation
- Back-up alarm
- Back-up lamp
- Batteries, 150 Ah/12 V x 2, 1,000 CCA
- Boom kick-out
- Bucket positioner
- Counterweight
- ECSS (Electronically Controlled Suspension System)
- Engine, Komatsu SAA6D107E diesel
- Engine shut-off system, electric
- Floor mat
- Front fenders
- Fuel pre-filter with water separator
- Hard water area arrangement
- (corrosion resister)
- KOMTRAX™
- Lift cylinders and bucket cylinder
- Loader linkage with standard lift arm
- Main monitor panel with EMMS (Equipment Management Monitoring System)
  - Gauges (Speedometer/tachometer, engine water temperature, fuel level, hydraulic temperature, torque converter temperature)
  - LCD displays (service meter/troubleshooting, shift indicator)
  - Lights (central warning, brake oil pressure, engine oil pressure, engine oil level, air cleaner restriction, parking brake, axle oil temperature, reverse cooling fan, oil change required, battery electrolyte level, radiator water level, engine preheat, battery charge, steering oil pressure, auxiliary steering, power mode, joystick steering option,
- directional indicator, auto shift, torque converter lockup option, shift hold, gear position, torque converter temperature, engine water temperature, turn signals, high beam, rpm/mpg display, hydraulic temperature, fuel level)
- PPC fingertip control, two levels
- Radiator mask, lattice type
- Rear defroster (electric)
- Rearview mirrors for cab
- Rear window washer and wiper
- ROPS/FOPS cab
- Seat, air suspension type with reclining
- Seat belt, 76 mm 3" wide
- Service brakes, wet disc type
- Starting motor, 24 V/7.5 kW
- Steering wheel, tilt/telescopic
- Sun visor
- Rims for 23.5-25-16PR L3 tires
- Transmission, 4 forward and 4 reverse
- Vandalism protection kit



## OPTIONAL EQUIPMENT

- 3-spool valve with lever and piping
- Additional counterweight
- AM/FM stereo radio cassette
- Cutting edge (bolt-on type)
- Emergency steering (SAE)
- Engine pre-cleaner with extension
- High-lift boom
- Limited slip differential (F&R)
- Lock-up clutch torque converter
- Monolever loader control with transmission F/R switch
- Power train guard
- Rear full fenders



## ALLIED ATTACHMENTS

- JRB bucket, General Purpose 4.0 yd<sup>3</sup> for use with coupler
- JRB bucket, Multi-purpose 3.25 yd<sup>3</sup> for use with coupler
- JRB fork, Construction 106" carriage, 60" tines for use with coupler
- JRB fork, Utility Pallet 96" carriage, 72" tines for use with coupler
- JRB boom-Extendable 3 section, 13' 7" extension for use with coupler
- JRB hydraulic quick coupler
- Loadrite weighing system, Force model
- Loadrite weighing system, Pro model
- Loadrite weighing system, Printer, LP950
- Loadrite weighing system, Pro model with Material Management System

AESS711-03

©2008 Komatsu America Corp. Printed in USA

K12(5M) C

12/08 (EV-1)

# KOMATSU®